



Phone: 920-757-5440
 Fax: 920-757-5819
 Address: N1022 Quality Drive,
 Greenville, WI 54942
 Email: info@diamondh2o.com
 Website: diamondh2o.com

DFS-7,200 Reverse Osmosis System

Features:
 Included Pre-Filter, High Flow, Low Energy Membranes,
 Fiberglass Membrane Housings, Programmable Automatic
 Membrane Flush, Low Inlet Water Pressure Safety Shut-Off,
 Programmable Automatic System Re-Start

Plumbing

RO Permeate and Concentrate
 Outlet: Both 1/2" OD JACO

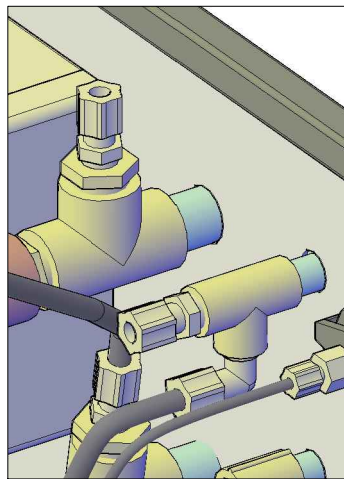

Permeate Flow Meter
 Concentrate Flow Meter

RO Inlet: 1.0" FPT

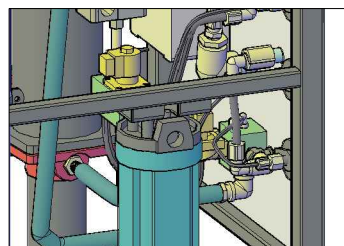

Flow Rates:

Supply (Feed Water): 7.4 GPM
 Permeate (Product): 5.1 GPM
 Concentrate (Reject): 2.3 GPM
 Production: 7,200 gpd
 Membranes Included: 3

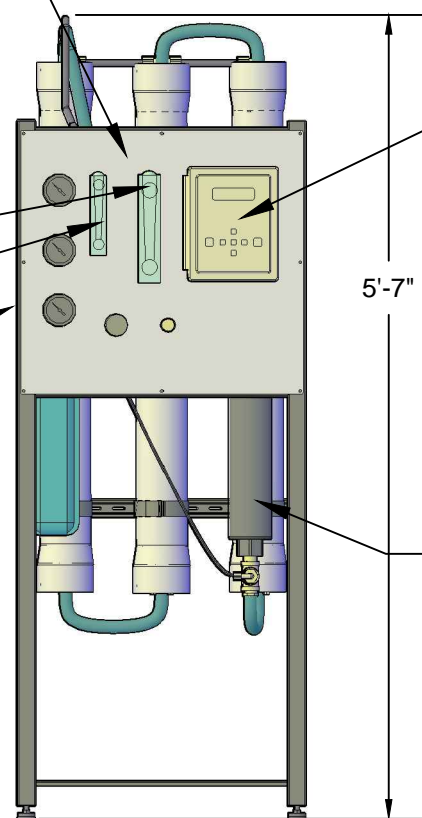
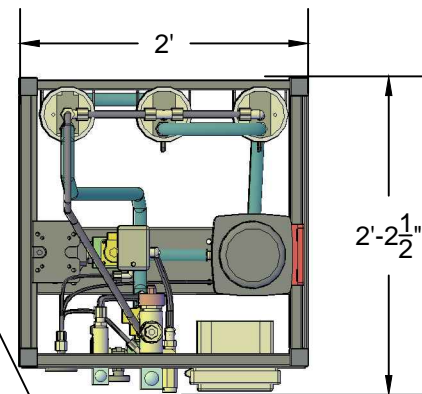

DCF6-200-100 AC Carbon Filter

Includes: 2.0 CuFt of Media
 Service Flow Rate: 6 gpm
 Peak Flow: 8 gpm
 Drain Flow: 6.5 gpm
 Weight: 125 lbs

Supply: 110 V, 1φ, 4A
 Standard 110V receptacle to accept a wall plug-in transformer
 (System is supplied with 10' electrical cord & plug)

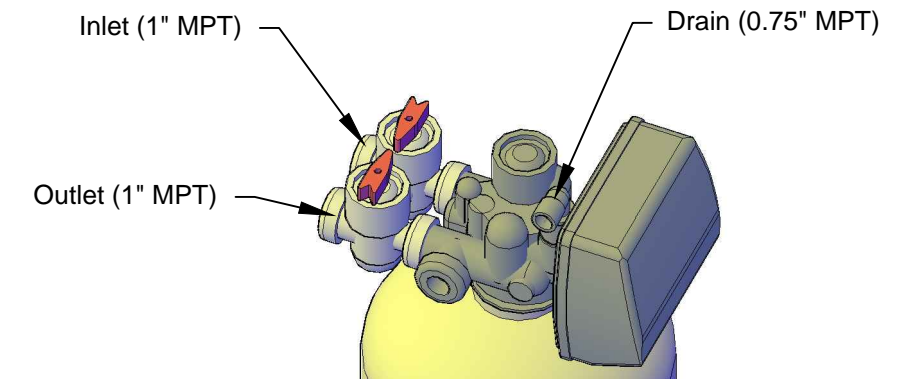

Footprint

24" W x 26.5" D x 67" H

Electrical

DFS-14400 Controller
 Requires 220VAC Power Supply
 Includes 6' Power Cord and Male Plug

Product Display

RO Status, Permeate TDS & Temperature,
 Feed Water TDS, Percent Reject, RO Time



Internal Pump (2.5 HP)

	230V	230V	460V
Phase (φ):	1	3	3
Max Load (A):	10.4	6	3
Branch Fuse Rating (A):	15	15	15
0-100' AWG:	14	14	14
Inlet Size:	1"		
Outlet Size:	1"		

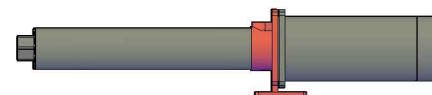

BACKWASHING (Pre-Treat)



OPERATION



MICROSWITCH
 Part #: 65-0026-XX
 (Backwashing)
 Plugs into back of
 RO System Control

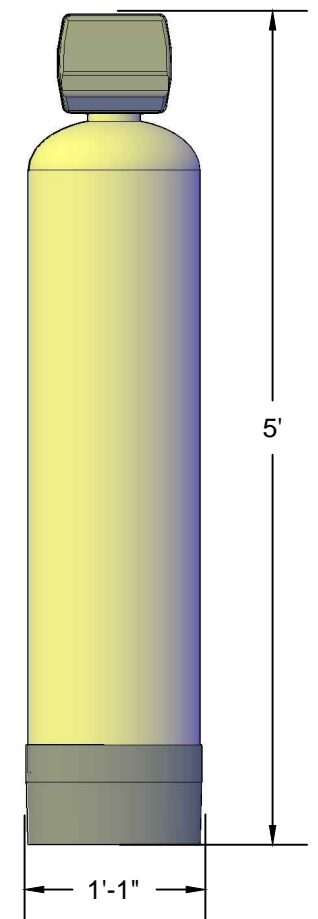

This drawing and design are the property of Diamond H2O and is not to be reproduced in whole, part, or employed for any other purpose than specifically permitted in writing by Diamond H2O. Dimensions are approximate.