



Phone: 920-757-5440  
 Fax: 920-757-5819  
 Address: N1022 Quality Drive,  
 Greenville, WI 54942  
 Email: info@diamondh2o.com  
 Website: diamondh2o.com

## DWM-2,400 Reverse Osmosis System

Features:  
 Included Pre-Filter, High Flow, Low Energy Membranes,  
 Fiberglass Membrane Housings, Programmable Automatic  
 Membrane Flush, Low Inlet Water Pressure Safety Shut-Off,  
 Programmable Automatic System Re-Start

### Plumbing

RO Permeate and Concentrate  
 Outlet: Both 1/2" OD JACO

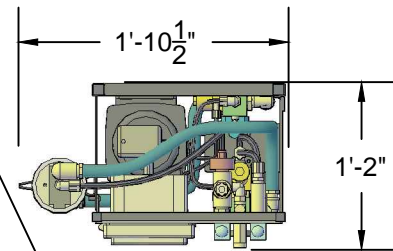
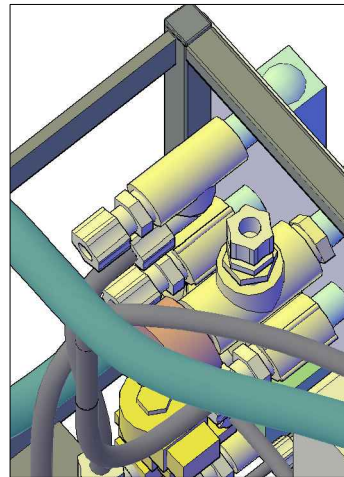

Permeate Flow Meter  
 Concentrate Flow Meter

RO Inlet: 1.0" FPT

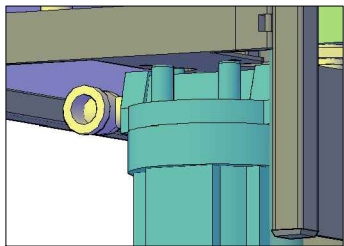

**Flow Rates:**  
 Supply (Feed Water): 2.8 GPM  
 Permeate (Product): 1.7 GPM  
 Concentrate (Reject): 1.1 GPM  
 Production: 2,400 gpd  
 Membranes Included: 1

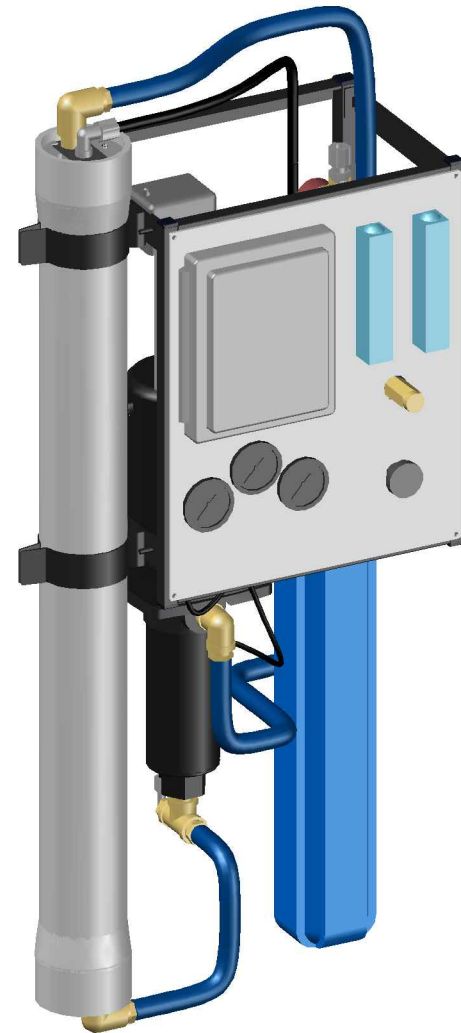
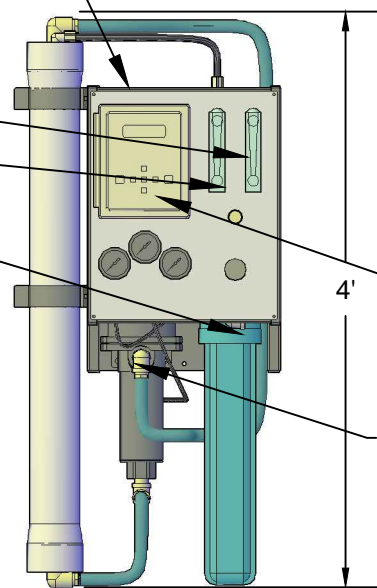

### Footprint

22.5" W x 14" D x 48" H



### Product Display

RO Status, Permeate TDS & Temperature,  
 Feed Water TDS, Percent Reject, RO Time

### Electrical

#### DWM-4800 Controller

Requires 120/230V Power Supply (Switch inside)  
 Includes 10' Power Cord and Male L6-20 Plug

#### Internal Pump (1.0 HP)

	230V	230V	460V
Phase (φ):	1	3	3
Max Load (A):	9.6	4.7	2.35
Branch Fuse Rating (A):	15	15	15
0-100' AWG:	14	14	14
Inlet Size:	3/4"		
Outlet Size:	3/4"		

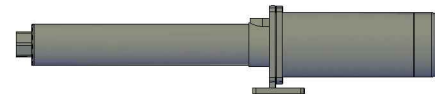

## DCF6-100-100 AC Carbon Filter

Includes: 1.0 CuFt of Media  
 Service Flow Rate: 3 gpm  
 Peak Flow: 6 gpm  
 Drain Flow: 5.3 gpm  
 Weight: 70 lbs

Supply: 110 V, 1φ, 4A

Standard 110V receptacle to accept a wall plug-in transformer  
 (System is supplied with 10' electrical cord & plug)

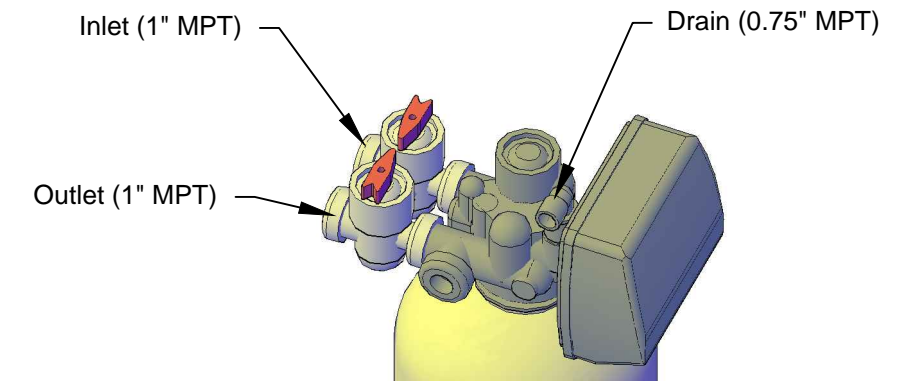

#### BACKWASHING (Pre-Treat)



#### OPERATION



**MICROSWITCH**  
 Part #: 65-0026-XX  
 (Backwashing)  
 Plugs into back of  
 RO System Control

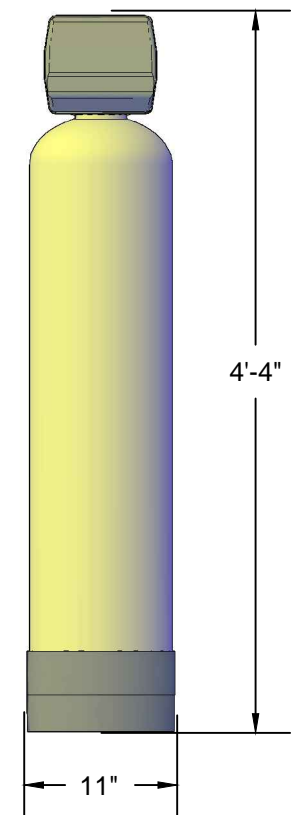

This drawing and design are the property of Diamond H2O and is not to be reproduced in whole, part, or employed for any other purpose than specifically permitted in writing by Diamond H2O. Dimensions are approximate.