

DROP

PROTECT WHAT MATTERS



Installation Manual

Pump Controller

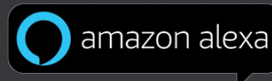
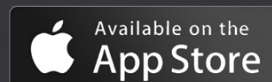

INTRODUCTION

Thank You for Purchasing a DROP System!

We know you'll love your leak detection ability and water conservation benefits of your new DROP Water Management System from Chandler Systems. Protecting your home and conserving water are just a few of the ways that the DROP Water Management System can improve your water system.

Be sure to check out the dropconnect.com website periodically for more information about additional DROP products as they are released.



833.BUY.DROP
(833.289.3767)



dropconnect.com

To further help you operate your new DROP system, we have provided you with many other resources for you to learn more. Feel free to call Chandler Systems when you need additional help. We also have many resources located on our website including instructional videos, and images.

DROP Connect is also active on various social media pages! Feel free to follow us for the most up to date information and news!



@dropconnect

Privacy Statement

For more information about privacy, visit our [privacy policy](https://dropconnect.com/sites/default/files/DROP-Privacy-Statement.pdf) (<https://dropconnect.com/sites/default/files/DROP-Privacy-Statement.pdf>) online.

DROP Patents

For the most up-to-date list of patents, visit our patents on our website: <https://dropconnect.com/patents>.

FCC Compliance Statement:

https://dropconnect.com/sites/default/files/FCC_Compliance_Statement.pdf

Industry Canada Compliance Statement:

https://dropconnect.com/sites/default/files/Industry_Canada_Compliance_Statement.pdf

TABLE OF CONTENTS



Introduction.....	2
Table of Contents.....	3
About Your System.....	4
Contents of Carton.....	5
Warnings.....	6
Installation Instructions.....	9
The DROP Remote.....	18



ABOUT YOUR SYSTEM

Your DROP Home Protection Valve uses advanced technology to protect your home from leaks, and save you money, all while providing years of trouble-free operation.

Additional Features You'll Find on Your DROP Pump Controller System

- **Pressure Monitoring and Pump Control:** Turns on and off a pump based on water pressure settings and readings. Records pressure data over time for a quick look at what has been happening recently on your system.
- **Water Usage Monitoring:** DROP monitors your water usage and provides real time information including: current water flow, peak flow today, daily average of the last 90 days, as well as many useful historical charts. The pressure switch has an optional water meter input. Note: If you have another DROP product that meters water (such as a softener or a filter), you may not need a water meter connected to your Pump Controller.
- **Pump Protection**
 - Monitor pump current and protect the pump from overloads.
 - Records peak and average motor current, number of pump cycles and cycle length and frequency.
 - Monitor incoming voltage and protect the pump in high or low voltage conditions by not turning on the pump.
 - Monitors pressure and motor current to detect pump run dry conditions and open discharge conditions.
 - Short cycle notification to indicate pressure tank or other equipment failures.
- **Home Protection**
 - Monitors for local leaks using a leak detection probe or cable that is connected on the underside of the Pump Controller housing.
 - Monitors water flow by connecting a water meter to the appropriate connection on the underside of the housing.
 - Monitors temperature of the general area to protect from freezing conditions.
 - Shuts the pump off if a leak is detected by any DROP component in the system.
 - App can be used to shut off the pump from anywhere that you have an internet connection. (The DROP system must have an active internet connection for this feature).
- **Connects to the DROP system and DROP App:** Allows a user full access to the information and settings that the pressure switch can provide. This gives the user the complete ability to adjust the settings and protections according to their application.
- **Automatically integrates with other components on your DROP system:** DROP is a water management system that integrates all the water related devices in your home including: water softeners, backwashing filters, leak detectors, sump pump alarms, and many more to come!

CONTENTS OF CARTON



Contents of Carton

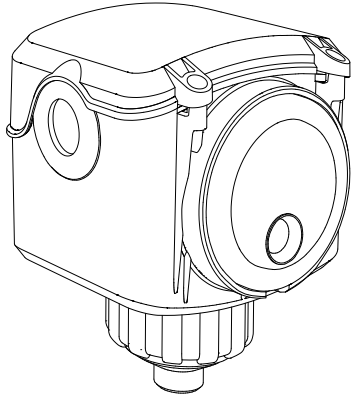

PUMP CONTROLLER

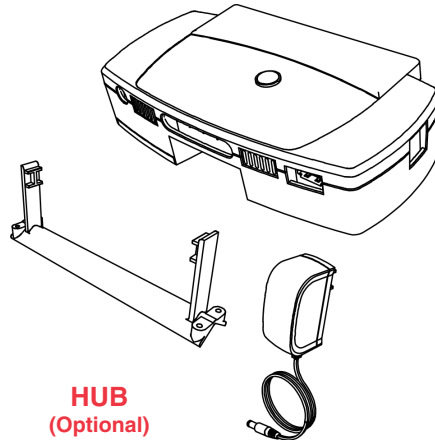

HUB
(Optional)

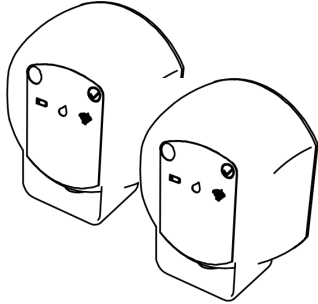

LEAK DETECTORS
(Optional)

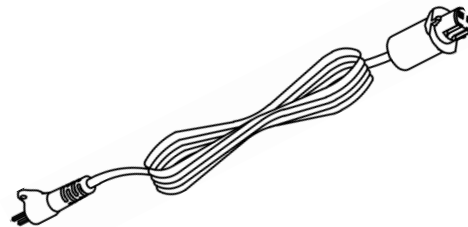

LEAK PROTECTION CABLE
(Optional)

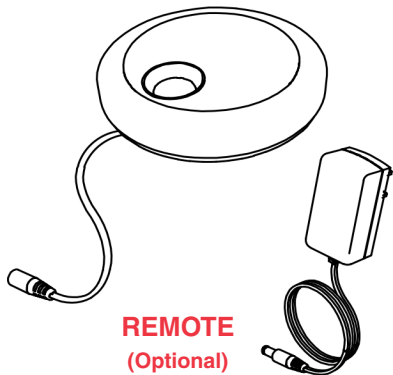

REMOTE
(Optional)

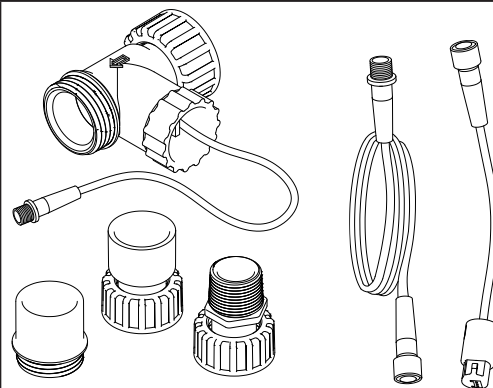

WATER METER & EXTENSION CABLE
(Optional)

WARNINGS

Precautions

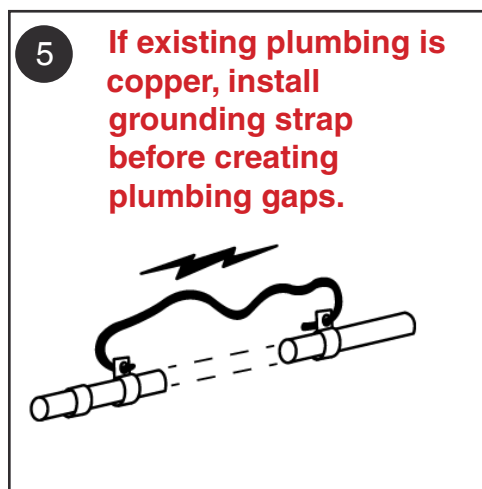
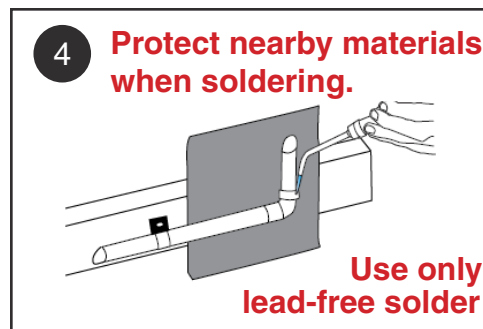
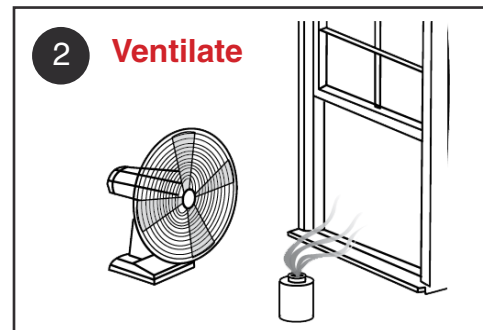

WARNINGS



WARNING: Read carefully the product installation & operation instructions. Failure to follow the instructions and warnings in the manual may result in serious or fatal injury and/or property damage and will void the product warranty. This product must be installed by a qualified professional. Follow all applicable local and state codes and regulations. In the absence of such codes, follow the current editions of the National Plumbing Code and National Electrical Code (NEC), as applicable. Failure to properly size the system or follow instructions in the manual may result in excessive strain on the system and may lead to product failure, leakage, flooding and/or property damage.

WARNING: This product is used in conjunction with a system containing a tank under pressure, which may over time corrode, weaken and burst or explode, causing serious or fatal personal injury, leaking or flooding and/or property damage.

DANGER: EXPLOSION HAZARD: When the well tank has been in service and a change to a higher pre-charge pressure is necessary due to a required change in the pressure switch setting, failure to follow instructions below can cause a rupture or explosion, possibly causing serious or fatal personal injury and/or property damage.

- Do not adjust or add pressure if there has been a loss of air.
- Do not adjust the pre-charge pressure if there is visible exterior corrosion.
- Do not adjust the pre-charge pressure if there has been a reduction of the pump cycle time or the pre-charge pressure compared to its initial setting. This is because a reduction in pump cycle time can result from loss of tank air pressure which can mean there may be internal corrosion. Any re-pressurization or additional pressure could result in rupture or explosion.

WARNING: To minimize risk, a licensed professional must install and periodically inspect and service the system, including the DROP pump controller, yearly and more frequently as the system ages.

WARNING: A drip pan connected to an adequate drain must be installed if leaking or flooding may cause property damage. Do not locate system in an area where leaking may cause property damage. Do not locate unit where it can be affected by flooding.

WARNING: This control can run pumps to pressures that may exceed the limitations of system components unless a relief valve capable of passing full pump flow at the maximum system pressure is installed. The maximum operating pressure rating of this pressure switch is 120 psi (827 kPa). Check local code requirement or maximum working pressure designated in the product manuals, whichever is less should be the maximum system pressure. Never set the operating pressure higher than that of the safe maximum system capacity.

WARNING: This control can be adjusted to a narrow pressure differential. An improperly sized tank can cause the pump to cycle frequently and lead to pump damage. This may require a larger pressure tank than is normally used.

WARNING: Do not expose system to freezing temperatures or temperatures in excess of 120°F (49°C).

CAUTION: Do not touch an operating motor. Modern motors can operate at high temperatures. To avoid burns when servicing a pump, allow it to cool for 20 minutes after shutdown before handling.

WARNINGS

CAUTION: Use this Pump Controller only in systems that pump water.

CAUTION: Do not use Vaseline or any petroleum-based lubricants on O-rings or rubber seals. Only use food-grade silicone lubricant.

CAUTION: Do not use pipe dope or any sealant other than Teflon tape on threaded connections. Threads on the tool free connection nuts do not require any tape because they use an O-ring seal. Tape is only required on the 1/4" NPT pipe connection.

A water test must be taken before installation of any water treatment equipment. The water quality can significantly influence the life of your system. You should test for corrosive elements, acidity, total solids and other relevant contaminants, including chlorine and treat your water appropriately to ensure satisfactory performance and prevent premature failure.

CALIFORNIA PROPOSITION 65 WARNING: This product can expose you to chemicals including lead, which is known to the State of California to cause cancer and birth defects or other reproductive harm. For more information go to www.P65Warnings.ca.gov.

WARNING: Use only lead-free solder and flux for all sweat-solder connections, as required by state and federal codes.

ELECTRICAL SAFETY

DANGER: ELECTROCUTION HAZARD: Must be installed by a qualified professional. First disconnect all electrical power before servicing. For your safety, the installation and operation instructions must be followed to minimize the risk of electric shock, property damage or personal injury.

WARNING: Unit must not be supported solely by the electrical conduit.

CAUTION: Systems with metallic conduit as grounding conductor (EMT, RMC, IMC, ETC): Electrical bonding between conduit connections is not automatic and must be provided as part of the installation. A bonding kit can be ordered separately.

CAUTION: The DROP pump controller has a Type 3R environmental rating. Watertight conduit connections must be used when exposed to direct weather, moisture or high humidity in order to maintain this rating.

The DROP Pump Controller is rated for Type 1 and 3R environments. If installed in a 3R environment a 1/8" drain hole should be drilled into the bottom of the enclosure in the location shown below. The installer should use caution when making this hole to only penetrate the housing wall and not unnecessarily plunge the drill bit deep into the enclosure interior.

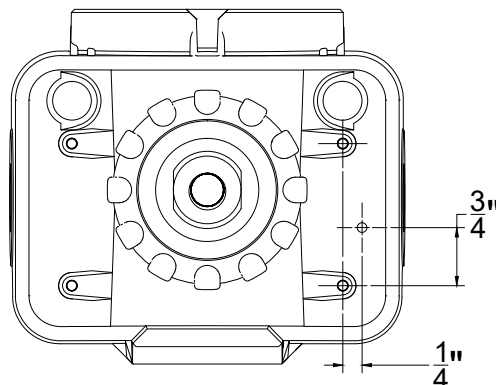



INSTALLATION INSTRUCTIONS

STEP 1: Plumb the Pump Controller into your water supply

Unpack equipment. Mount the 1/4" NPT stainless steel pump controller connection to the pressure tank tee using an appropriate length pipe nipple. Then insert the pump controller and tighten the plastic nut (hand tighten only).

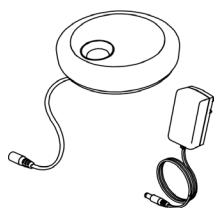
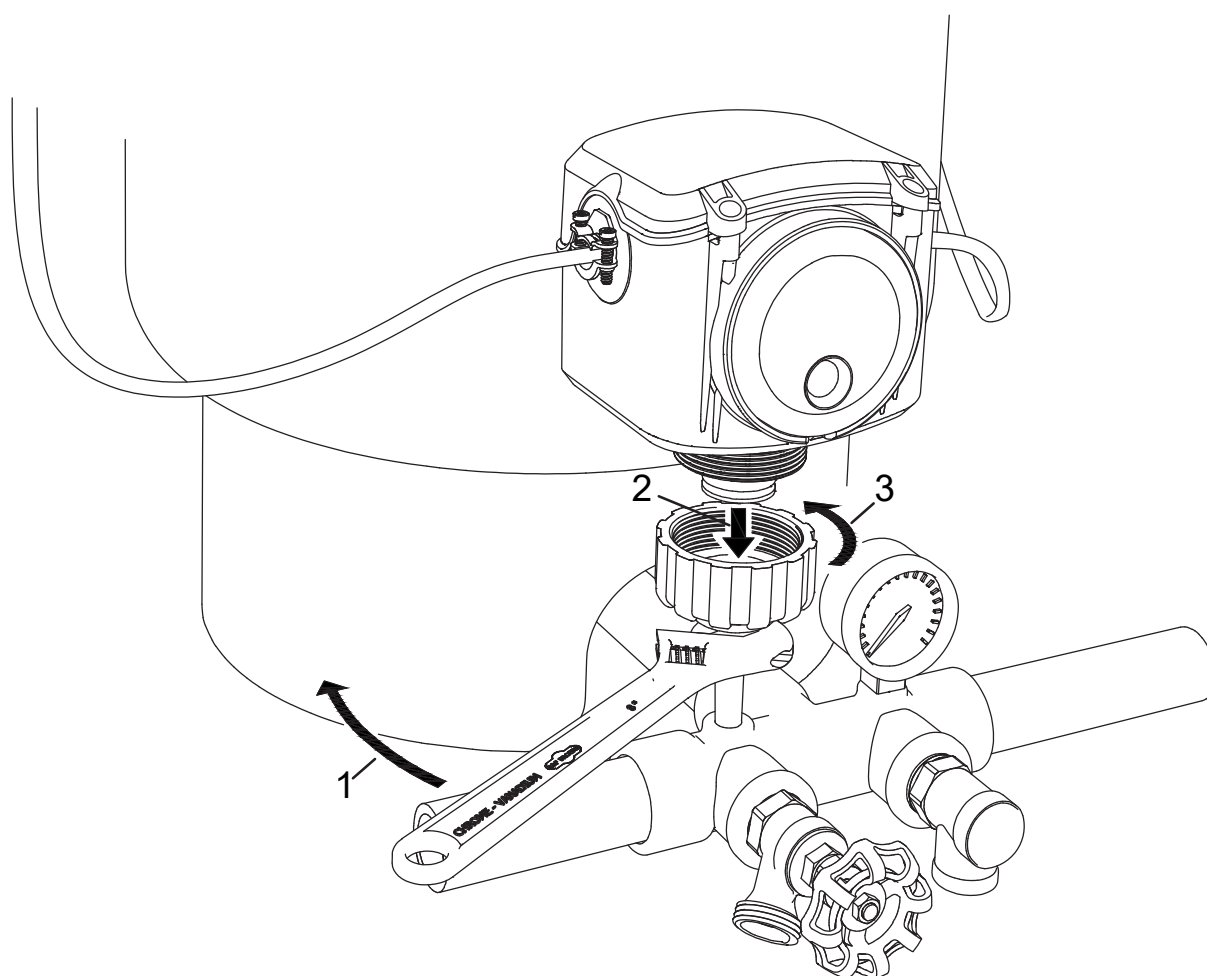

Remote
(Optional)



**Leak
Detector**
(Optional)

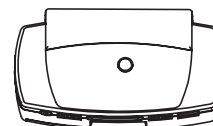

Hub
(required)

INSTALLATION INSTRUCTIONS

Installation with Optional Water Meter

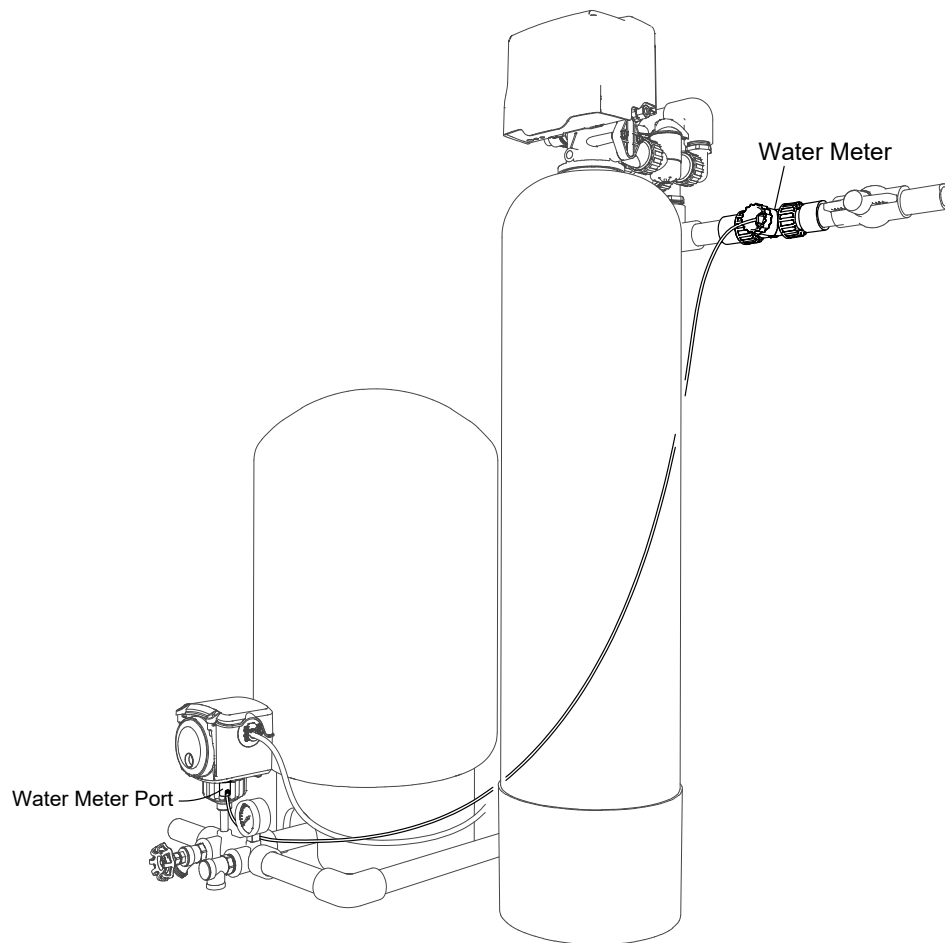

INSTALLATION INSTRUCTIONS



STEP 2: Connect Power Line and Pump Wire Load to the Pump Controller

Back View of Pump

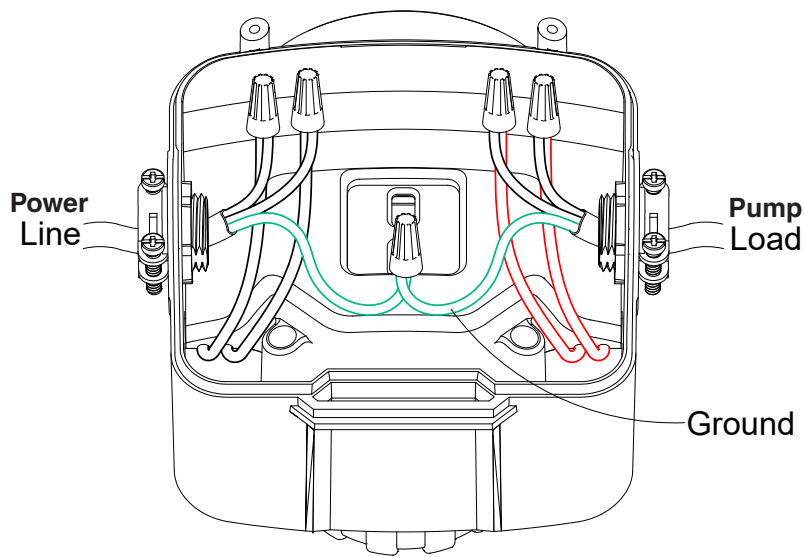

Front View of Pump

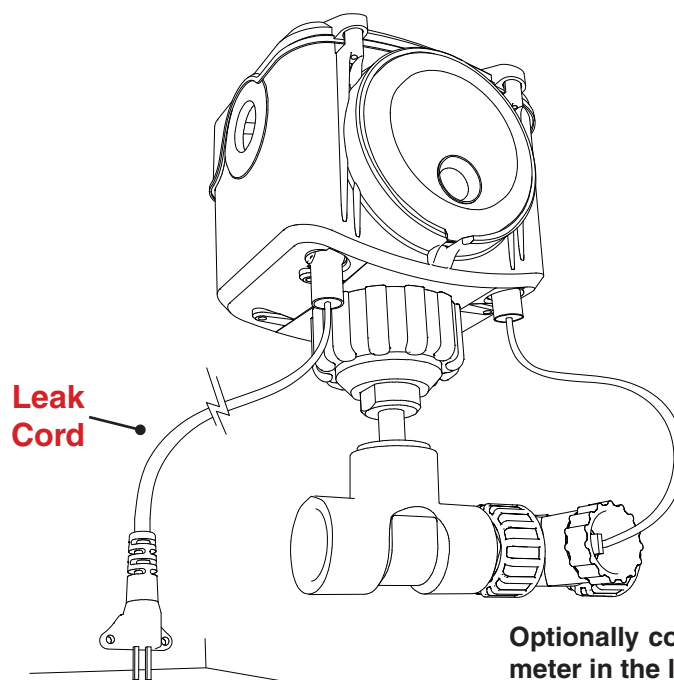

Optionally connect the leak cord and the water meter in the locations shown.

INSTALLATION INSTRUCTIONS

STEP 2: Continued



This product must be installed by a qualified professional. Follow all applicable local and state codes and regulations. In the absence of such codes, follow the current editions of the National Plumbing Code and National Electrical Code (NEC), as applicable.

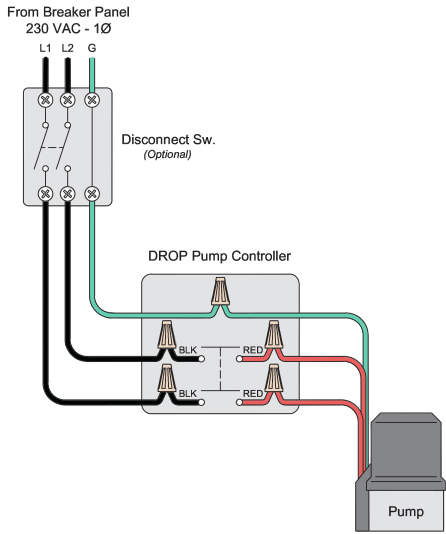

230VAC 2-Wire Pump Wiring Diagram (P/Ns: DPC-230-25, DPC-230-30)

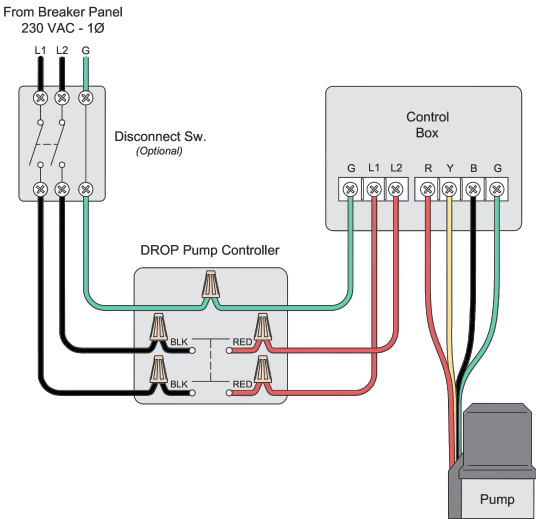

230VAC 3-Wire Pump Wiring Diagram (P/Ns: DPC-230-25, DPC-230-30)

INSTALLATION INSTRUCTIONS



STEP 2: Continued

*

This product must be installed by a qualified professional. Follow all applicable local and state codes and regulations. In the absence of such codes, follow the current editions of the National Plumbing Code and National Electrical Code (NEC), as applicable.

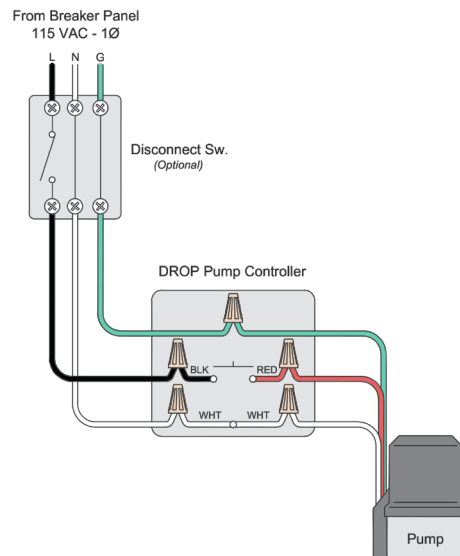

115VAC 2-Wire Pump Wiring Diagram (P/Ns: DPC-115-25, DPC-115-30)

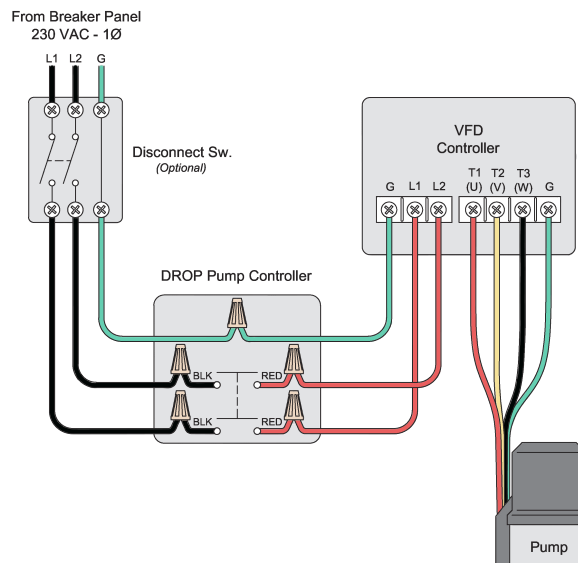

230VAC VFD Wiring Diagram (P/Ns: DPC-230-25, DPC-230-30)

INSTALLATION INSTRUCTIONS

STEP 3: Download the DROP Connect Mobile App

STEP 4: Determine where you want to locate the HUB and Optional REMOTE

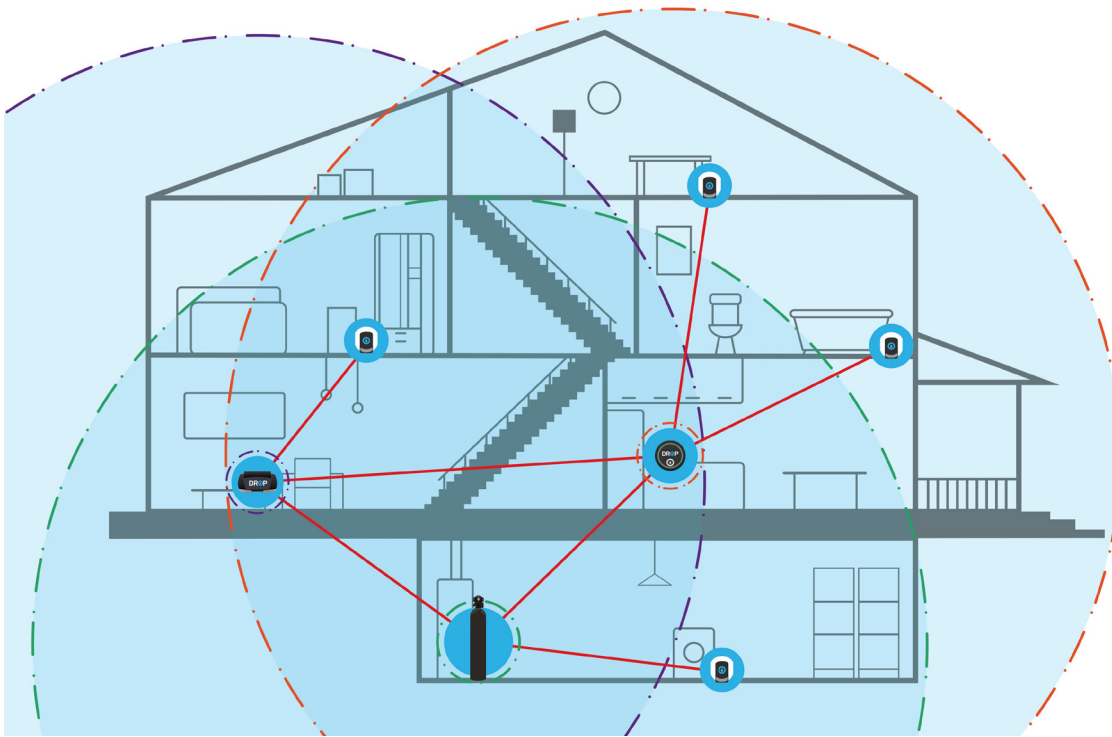

As shown above, all DROP devices that plug into 120 volt outlets expand the DROP Link mesh network. When placing the DROP Hub and Remote, keep in mind that installing them in separate areas of the home will expand the network. This is important to consider if you have leak detectors that are located in far extremes of the home.

*

If you wish to connect your system to local WiFi for remote control and notifications, please install the DROP Hub in a location that has a good WiFi signal.

INSTALLATION INSTRUCTIONS



STEP 5: Follow Mobile Onboarding in the DROP Connect App

See Users Guide for detailed instructions

STEP 6: Add & Name Each Device

WARNING: Before continuing, check for open drain valves or other sources of flooding before starting unit. Once you are done configuring your pump switch you can turn the water state back to ON and test your pump installation.

The default pressure settings for the DROP pump controller are cut-in at 30 psi and cut-out at 50 psi. When the pump controller is powered up for the first time it will run the pump to the cut-out pressure. Make sure your system is ready for your pump to run when you apply power to the pump controller. You can adjust the settings to your preference once the system is powered up.

If these default settings are not compatible for your system, disconnect the pump wires from the pump controller before you power it up for the first time. Power it up and adjust the settings according to the needs of your system. Then shutoff power to your pump controller, reconnect your pump and finally turn power back on.

STEP 7: Place Leak Detectors (Optional)



See "Leak Detectors" in Users Guide for detailed instructions

INSTALLATION INSTRUCTIONS

STEP 8: Configure the System

Adjust the settings according to your needs. To learn more about a setting touch the info icon next to the setting.



DEVICES > PUMP CONTROLLER > ADVANCED
(Navigation description examples can be found in the User Guide)

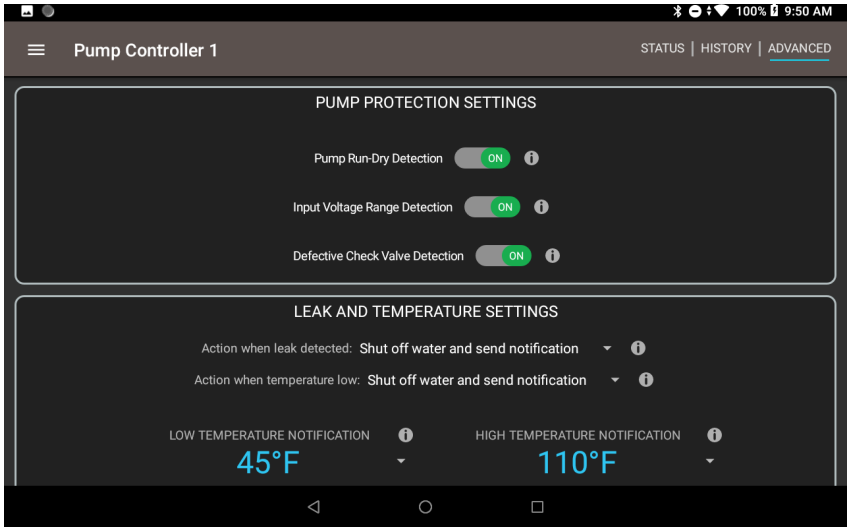

The DEVICES screen allow you to customize how your system operates. See “Pump Controller” Section of Users Guides for more information.

DEVICES > PUMP CONTROLLER > STATUS
(Navigation description examples can be found in the User Guide)

INSTALLATION INSTRUCTIONS



STEP 8: Continued

First, select the pump controller operation mode:

Normal Pump Controller – In this mode, the pump controller will start and stop the pump maintain water pressure between the low and high pressure setpoints. This is the default setting and the most typical application. Set the Low Pressure Start and High Pressure Stop settings to the pressures that will start and stop the pump.

VFD Controller – In this mode, the pump controller supplies power to a Variable Frequency Drive (VFD) that controls the well pump. The High Pressure Stop setting should be set higher than the normal operating pressure range of the VFD and serves as an emergency stop if the VFD were to malfunction. For example, if the VFD operating pressure range is 50-60 PSI, set the High Pressure Stop on the DROP pump controller to 70 PSI. If the system pressure rises above 70 PSI, the DROP pump controller will disconnect the VFD power and notify you that the pump has been disabled.

Alternating Pump Controller – In this mode, multiple pump controllers in alternating mode will take turns running the pumps. This is accomplished by automatically lowering the Low Pressure Start setting by 5 PSI on the pumps that are not the lead pump. After each pump cycle, the lead unit is advanced to the next available pump controller in Alternating Pump Controller mode. This mode can be useful when drawing water from multiple weak wells.

Next, set the installed flow meter type if a meter was provided with the pump controller. Most installations will use a 1" flow meter, but 1.5", 2" and 3" commercial meters are also available. Note that installing a flow meter is optional.

Next, set the Pump Full Load Amps (FLA) setting according to the full-load current draw specified by the pump manufacturer. This setting is used to predict a thermal overload and protect the pump.

Adjust the remaining settings according to your needs. To learn about a setting, touch the info icon next to the setting or refer to the DROP user guide.

THE DROP REMOTE



The DROP Remote is sold as an optional accessory.

In addition to acting as a DROP Link mesh network extender, the DROP Remote has additional features:

At a glance the remote can provide the status of your water system through color codes.

Color codes for normal operation

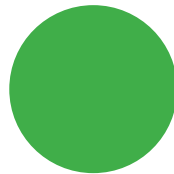

Water is in Service

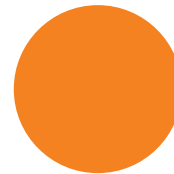

Water is Shutoff

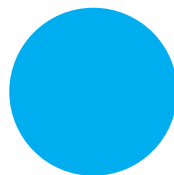

Slow blinking indicates you have a notification in your DROP App that has not been seen

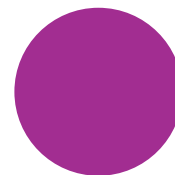

Flashes indicate that the DROP Remote is communicating with other devices

To turn off water in your home, place your finger on the water DROplet button for about 2 seconds. Once the lights turn orange, remove your finger.

If your system is in the Shutoff mode and you would like to turn your water back on, place your finger on the DROplet button for about 2 seconds. When it turns to green, remove your finger and, your water will turn back on.



WATER MANAGEMENT SYSTEMS

This warranty cannot be transferred - it is extended only to the original purchaser or first user of the product. By accepting and keeping this product, you agree to all of the warranty terms and limitations of liability described below.

Important Warning: Read carefully the DROP Water Management Systems Equipment Installation, Operating and Maintenance Instructions Manual to avoid serious personal injury and property HAZARDS and to ensure safe and proper care of this product.

*FOR AS LONG AS YOU OWN AND LIVE IN YOUR SINGLE FAMILY HOME, this warranty covers your water treatment equipment, if you are the first user of this DROP Water Treatment Systems equipment and purchased it for single family home use - subject to all of the conditions, limitations and exclusions listed below. Purchasers who buy the DROP equipment for other purposes, and other component parts are subject to more limited warranties and you should read all of the terms included in this form to make sure you understand your warranty.

What is covered by this warranty?

Chandler Systems, Inc. warrants that at the time of manufacture, the DROP equipment shall be free from defects in material and workmanship as follows:

Product	Warranty
Residential Mineral Tank	10 Years
DROP Control Valves	5 Years
DROP Pump Controllers	5 Years
DROP Home Protection Valve	5 Years
Brine Tank	5 Years
DROP Hub and Remote	1 Year
DROP Wireless Low Salt Alarm	1 Year
Other Accessories and Parts	1 Year
Brine Tank Components	1 Year

* This warranty does not include media and/or cartridge filter elements.

Additional Terms & Conditions

What Chandler Systems Inc will do if you have a covered warranty claim; Chandler Systems Inc will at its discretion either make repairs to correct any defect in material or workmanship or supply and ship either new or used replacement parts or products. Chandler Systems, Inc. will not accept any claims for labor or other costs.

Additional Exclusions and Limitations

This warranty is non-transferable and does not cover any failure or problem unless it was caused solely by a defect in material or workmanship. In addition, this warranty shall not apply:

- If the equipment is not correctly installed, operated, repaired and maintained as described in the Installation, Operating & Maintenance Instructions Manual provided with the product.
- Defects caused as a direct result of the incoming water quality
- If the DROP equipment is not sized appropriately for the intended job.

- To any failure or malfunction resulting from abuse (including freezing), improper or negligent; handling, shipping (by anyone other than DROP)
- If the unit has not always been operated within the factory recommended temperature limits, and at a water pressure not exceeding 125 psi, during storage, use, operation, accident; or alteration, lightning, flooding or other environmental conditions.
- To any failure or malfunction resulting from failure to operate the system with potable water, free to circulate at all times; and free of damaging water sediment or scale.
- This warranty does not cover labor costs, shipping charges, service charges, delivery expenses, property damage, administrative fees or any costs incurred by the purchaser in removing or reinstalling the water management equipment.
- The warranty does not cover any claims submitted more than 30 days after expiration of the applicable warranty, and does not apply unless prompt notice of any claim is given to an authorized DROP Dealer or to DROP or a designated contractor is provided access to the installation and to the water treatment equipment.

THESE WARRANTIES ARE GIVEN IN LIEU OF ALL OTHER EXPRESS WARRANTIES. NO DROP REPRESENTATIVE OR ANY OTHER PARTY IS AUTHORIZED TO MAKE ANY WARRANTY OTHER THAN THOSE EXPRESSLY CONTAINED IN THIS WARRANTY AGREEMENT.

Additional Warranty Limitations

ANY IMPLIED WARRANTIES THE PURCHASER MAY HAVE, INCLUDING THE IMPLIED WARRANTIES OF MERCHANTABILITY AND FITNESS FOR A PARTICULAR PURPOSE, SHALL NOT EXTEND BEYOND THE APPLICABLE TIME PERIODS SPECIFIED ABOVE. Some states do not allow limitations on how long an implied warranty lasts, so the above limitations may not apply to you.

Limitations of Remedies

The remedies contained in this warranty are the purchaser's exclusive remedies. In no circumstances will Chandler Systems, Inc. or the seller of the product be liable for more than, and purchaser-user's remedies shall not exceed, the price paid for the product. In no case shall Chandler Systems, Inc. or seller be liable for any special, incidental, contingent or consequential damages. Special, incidental, contingent and consequential damages for which Chandler Systems, Inc. is not liable include, but are not limited to, inconvenience, loss or damage to property, consequential mold damage, loss of profits, loss of savings or revenue, loss of use of the products or any associated equipment, facilities, buildings or services, downtime, and the claims of third parties including customers. Some states do not allow the exclusion or the limitation of incidental or consequential damages, so the above limitations or exclusion may not apply to you.

What to do if you have a problem covered by this warranty

Any warranty coverage must be authorized by Chandler Systems, Inc.. Contact the person from whom you purchased the product, who must receive authorization from a DROP Dealer.

If your product is new and not used and you wish to return it, contact your DROP Dealer.

Note: This equipment has been tested and found to comply with the limits for a Class B digital device, pursuant to part 15 of the FCC Rules. These limits are designed to provide reasonable protection against harmful interference in a residential installation. This equipment generates, uses and can radiate radio frequency energy and, if not installed and used in accordance with the instructions, may cause harmful interference to radio communications. However, there is no guarantee that interference will not occur in a particular installation. If this equipment does cause harmful interference to radio or television reception, which can be determined by turning the equipment off and on, the user is encouraged to try to correct the interference by one or more of the following measures:

- Reorient or relocate the receiving antenna.
- Increase the separation between the equipment and receiver.
- Connect the equipment into an outlet on a circuit different from that to which the receiver is connected.
- Consult the dealer or an experienced radio/TV technician for help.

Chandler Systems Inc.
710 Orange St.
Ashland, OH 44805

P. 1 833 BUY-DROP
www.dropconnect.com





